

产品尺寸图 (DIMENSION)

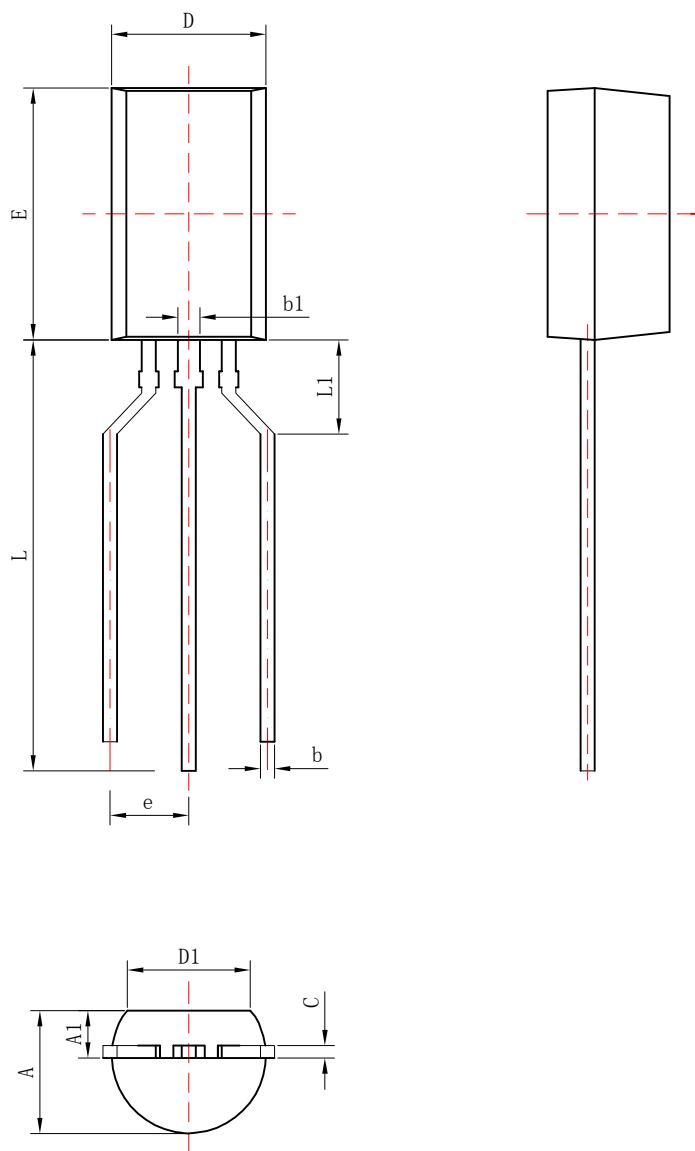

symbol	Dimensions In Millimeters			Dimensions In Inches		
	Min	Nom	Max	Min	Nom	Max
A	3.70	3.90	4.10	0.146	0.154	0.161
A1	1.40	1.50	1.60	0.055	0.059	0.063
b	0.35	0.45	0.55	0.014	0.018	0.022
b1	0.60	0.70	0.80	0.024	0.028	0.031
C	0.35	0.40	0.45	0.014	0.016	0.018
D	4.70	4.90	5.10	0.185	0.193	0.201
D1	3.80	-	-	0.150	-	-
E	7.80	8.00	8.20	0.307	0.315	0.323
e	2.40	2.50	2.70	0.094	0.098	0.106
L	13.20	13.70	14.20	0.520	0.539	0.559
L1	2.70	3.00	3.30	0.106	0.118	0.130

FSMC

图名 NAME	TO-92NL (青蛙脚)	图号 DWG. NO.	DD0080	SH 1 OF 1
材质 MATERIAL	Cu/Fe	REV.	B	
单位 UNITS	MM [INCH]	核准 APPROVE	审核 CHECKED	制图 DRAWN
日期 DATE	2019.08.23			第三角法
比例 SCALE	N. T. S.			